

# +SAFETY –TIME

The Joey's ability to bring tools or goods up and down from height while being able to drive from task to task allows workers to complete elevated work both more safely and more quickly. Built to ANSI 92.6 standards, the Joey reduces employer exposure to worker injuries resulting from the use of ladders or other fixed platforms and assists in their compliance with general OSHA regulations. Unlike some lightweight commercial products, the Joey was built from the ground up for the rigors of work, not the soft music of elevators. Point blank, this vehicle is highly productive and doesn't wobble.

## INFINITELY SAFER THAN LADDERS



As anyone who has worked overhead with tools, or been confronted with walking down a ladder with their hands full can tell you, ladders are unsafe by nature for many tasks. The steel I-beam channel mast on the Joey provides exceptional stability for operators while elevated, and has the largest platform in its class to bring materials, goods, or tools up and down from height. Additionally the fully enclosed operators compartment, behind the operator mast design, and optional fall restraint ensure that operators are secure and confident of their safety.

## 2X WORKER PRODUCTIVITY

The Joey can turn many two person tasks into one person tasks, and allows many one person tasks to be done twice as fast. With the available high speed option, the Joey can operate at up to 5 mph when at ground level, while automatically reducing travel speed at height. Precise electronic power steering and the ability to turn around in a 72" aisle, also make the Joey an extremely easy vehicle to maneuver. When compared to other competitive units that employ swivel casters, the Joey provides the best operator control, carries the largest payload, has the longest duty cycle, supports quick battery changes and simply outclasses the competition in regard to productivity.



# SPECIFICATIONS & FEATURES

## CAPACITY

- 1000 lbs. total vehicle capacity
- > 300 lbs. operators compartment
- > 500 lbs. front work platform
- > 200 lbs. rear "hide away" tray

## WEIGHT

2268 lbs. Chassis Only

## WHEELS / TIRES

- DRIVE - (1)9" x 3" polyurethane
- STABILITY - (2)3" x 2" polyurethane
- LOAD - (2)8" x 3" polyurethane

## BATTERY

Compartment: 29.1" x 7.9" x open. Anderson 175 Gray—A-11

## SPEED

- TRAVEL - Variable from 0 mph to 3.4 mph fully lowered (standard)
- Variable from 0 mph to 5.0 mph fully lowered (high speed option)
- Automatic speed reduction system when elevated
- 4 operator selectable speed settings
- LIFT - Up to 42fpm

## ELECTRICAL

24 volt ZAPI ACO travel and EPS ACO power steering controller with dash board display. LCD dashboard displays hour meter, battery state of charge, travel speed, drive wheel direction, speed settings, and diagnostic codes.

## MAST

Heavy duty I-beam design provides excellent stability at height. Steel mast channels and side mounted lift cylinders increases platform capacity.

## CHASSIS

Three point chassis design with along with 180° drive motor steering arc provides exceptional maneuverability.

## OPERATOR COMPARTMENT

Ergonomic fingertip control for travel, lift, and lower functions provide the operator with logical intuitive drive characteristics while traveling at elevation or lowered. Roomy operator compartment is designed for productivity. Retractable compartment guard rails keep the operator secure.

## REGENERATIVE BRAKES

Regenerative braking is applied when the operator removes their hand from travel control or when travel speeds are reduced, Electromagnetic parking brake is applied after the truck is stopped.

## STANDARD FEATURES

- Electronic Power Steering
- Large Operators Compartment
- One Piece Powerhead Service Cover

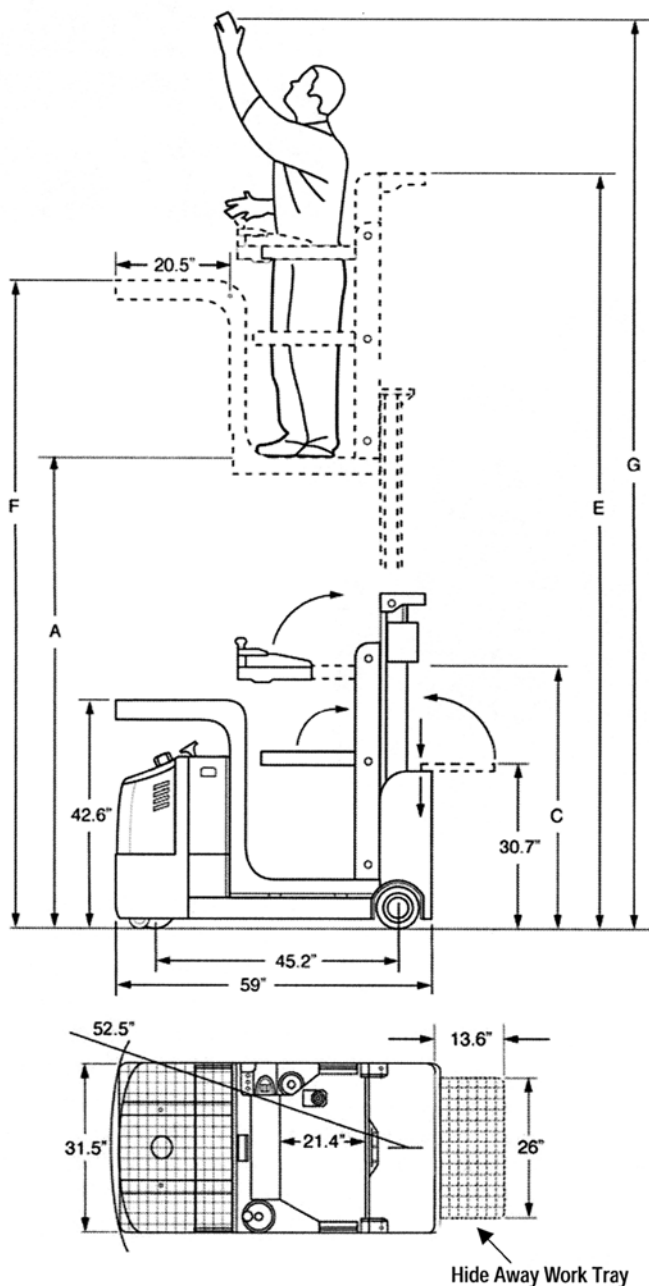

Model #	Mast	Lift Height	Col Height	Extended Height	Load Tray Height	Working Height	Weight Chassis Only
		A	C	E	F	G	
1000 Capacity = Personnel + Merchandise							
J1-86	Telescopic	86"	62.6"	141.0"	130.6"	165"	1950 lbs
J1-126	Triple Stage	126"	62.6"	178.6"	168.5"	203"	2268 lbs
J1-162	Triple Stage	162"	82.0"	216.0"	204.5"	239"	2610 lbs



Phone: 630-916-2600  
 Fax: 630-916-0657  
 E-mail: sales@bigjoeforklifts.com  
 Web: [www.bigjoeforklifts.com](http://www.bigjoeforklifts.com)

**ideas @ work**



**J1**  
**JOEY**  
TASK SUPPORT VEHICLE



# DRIVE TOW ELEVATE TASK SUPPORT VEHICLE

The Joey is a great alternative to a rolling ladder or larger equipment where elevation of personnel is required to complete a task. Compact and capable the Joey is highly maneuverable, intuitive to operate, and an excellent equipment choice in support of general overhead maintenance, inventory, or order picking duties.



*Multiple patents pending*

## OPTIONAL EQUIPMENT & ACCESSORIES



### OPTIONAL FALL RESTRAINT SYSTEM

Includes anchor point, harness and fixed length lanyard. Required if guard rails are ever to be raised (opened) while the operator's platform is above its fully lowered position.



### OPTIONAL BATTERY STAND

Supports side extraction of multiple battery packs or industrial batteries. Roller compartment with side gate is standard on all trucks.

## EXCLUSIVE TOWING OPTION.

Capable of towing up to 2,500lbs. the Joey's ability to drive, tow and elevate allows it to perform multiple duties with one piece of equipment or dramatically improve on tasks such as less than pallet quantity order picking. Bringing a rolling load along with an elevating vehicle can result in significant productivity gains and lower operating costs in all sorts of applications. Whether the Joey is used to support retail stores, parts facilities, ecommerce, production lines, or just for facility maintenance - the ability to drive, tow and elevate delivers a unique value.

*(Cart not included. Use caution when selecting towables to avoid damage to equipment or potential hazards.)*



# OVERVIEW & FEATURES



Extra large 500lb. capacity front load tray

Electronic power steering with AC drive delivers intuitive and accurate maneuverability

Durable steel frame protects the hideaway rear tray and supports an I-beam channel mast for superior stability at height.



LCD DASHBOARD WITH 4 OPERATOR SPEED SETTINGS



FINGERTIP ERGONOMIC CONTROLS



LARGE HIGH VISIBILITY OPERATORS COMPARTMENT

One piece cover provides excellent maintenance access to all drive line components

Big Joe exclusive 224AH AGM battery pack with 120v charger supports opportunity charging and provides up to 4 hours of continuous run time.

Low 9.5" step height allows for easy vehicle entry and exit



TURN AISLE